

Exposed Cistern **AQUABOX AIR**

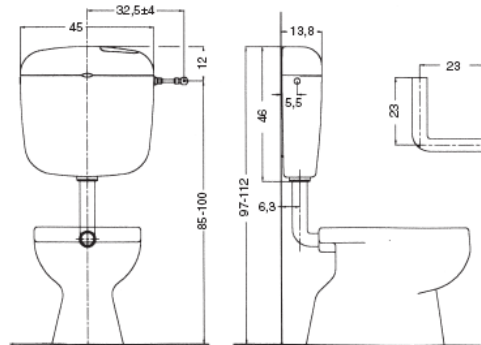

Field of application

- Exposed installation
- Installation for disabled

Features

- Exposed cistern with anti-condensation insulation
- equipped with quiet float valve compliance with DIN and NF standards
- pneumatic control by recessed, external push button or pedal
- side (left or right) or rear water inlet

Technical data

- | | |
|-----------------------------------|--------------|
| ○ Total capacity | Lt 12 |
| ○ Total flush volume adjustment | Lt 6-9 |
| ○ Internal diameter of flush pipe | mm 50 |
| ○ Average flush speed | l/s 2,0 |
| ○ Operation | Single flush |

Contents

- Flush pipe Ø50/Ø40
- Chromed angle valve 3/8"

Item

- | | |
|------------|----------------------|
| 15.00L/PNE | Aquabox Air external |
| 15.00L/PNI | Aquabox Air recessed |
| 15.00L/PNP | Aquabox Air pedal |

Certifications

The product complies with CE standards



(See attachment for declaration of performance)

ITS TODINI s.r.l. declares under its own exclusive responsibility that the above flush cisterns respect all the safety and functionality requirements regarding the use in sanitary plumbing as long as they are installed properly.

Product warranty

All models of exposed cisterns AQUABOX are guaranteed 2 years against material or workmanship defects

The warranty is valid from the date of purchase demonstrated, as long as installation instructions provided and correct mode of use are respected.

The warranty is void in case of damage caused by accident, misuse, unauthorized modification, improper installation or maintenance.

The duration of the rubber seals varies depending on local water conditions, so they are not covered by warranty.