

In wall cistern **HIDROBOX EVOLUTION**

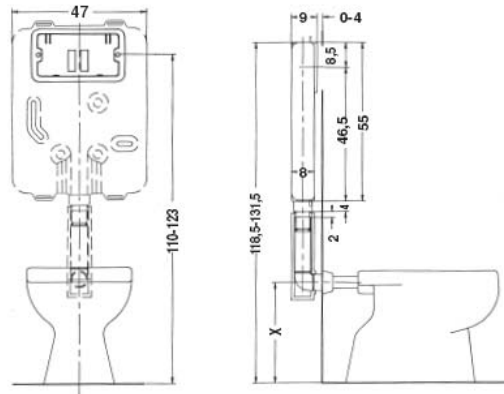

Field of application

- in wall installation
- installation in masonry walls
- for floor mounted toilets

Features

- in wall cistern with anti-condensation insulation
- front control plate
- fully inspected cistern (replacement of the flush valve and seal seat)
- equipped with quiet float valve compliance with DIN and NF standards

Technical data

- | | |
|-----------------------------------|------------|
| ○ Total capacity | Lt 10,5 |
| ○ Total flush volume adjustment | Lt 6-9 |
| ○ Short flush volume | Lt 3 |
| ○ Internal diameter of flush pipe | mm 50 |
| ○ Average flush speed | l/s 2,2 |
| ○ Operation | Dual flush |

Contents

- Insulated flush pipe
- Connection pipe to wc
- Stop valve
- protection cover of the inspection opening
- fixing bolts and brackets

Item

14.00E/DC Hidrobox Evolution