

## Module for light walls IDEALITE *BLU*

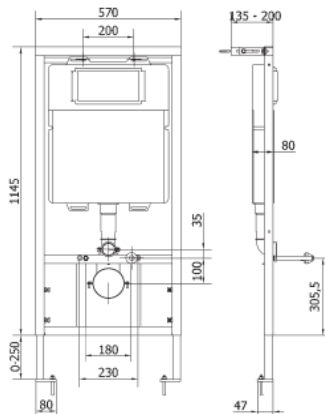

### Field of application

- Wall concealed installation
- Installation in light and masonry walls, self-supporting single and double walls
- For wall hung WC, adjustable distance 18-23cm
- Screed deepness from 0 to 25 cm

### Features

- in wall cistern with anti-condensation insulation
- front control plate
- equipped with quiet float valve compliance with DIN and NF standards, and with sanitizing liquid dispenser.
- equipped with quiet float valve compliance with DIN and NF standards
- Powder coated steel frame
- Fixing collar for drain pipe

### Technical data

- |                                 |            |
|---------------------------------|------------|
| ○ Total capacity                | Lt 10,5    |
| ○ Total flush volume adjustment | Lt 6-9     |
| ○ Short flush volume            | Lt 3       |
| ○ Flush pipe inside diameter    | mm 50      |
| ○ Average flush speed           | l/s 2,2    |
| ○ Operation                     | Dual flush |
| ○ Dispenser tank capacity       | ml 500     |

### Contents

- Insulated flush pipe
- Wc connection tube
- Angle stop valve
- Protection cover for inspection hole
- Fixing bolts and brackets
- Wall drain pipe Ø90

### Item

20.25B Idealite